

SPROCKETS and IDLER WHEELS for crate conveyor chains





SPROCKETS

Material: polyamide.

Notes: sprockets are supplied with standard 20 mm bore and can be produced on request with a finished bore according to your drawing.

Application: chains series 600.

 For tolerances and dimensions see pages 332 - 333

 For chains type see pages 118 → 120

 For chemical resistance see pages 336 - 337

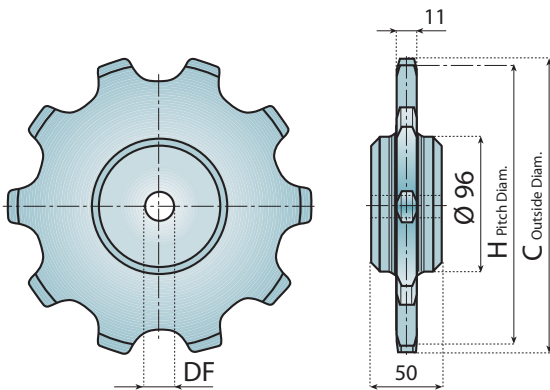

| CODE | Material | Z | C mm | H mm | DF mm | Weight Kg |
|-------|-----------|----|------|------|-------|-----------|
| 12326 | POLYAMIDE | 8 | 172 | 166 | 20 | 0.60 |
| 12327 | | 10 | 215 | 205 | | 0.80 |
| 12328 | | 12 | 256 | 246 | | 1.25 |
| 12329 | | 14 | 297 | 286 | | 1.85 |



SPROCKETS

Material: polyamide.

Notes: sprockets are supplied with standard 20 mm bore and can be produced on request with a finished bore according to your drawing.

Application: chains series 1400.

 For tolerances and dimensions see pages 332 - 333

 For chains type see pages 121

 For chemical resistance see pages 336 - 337

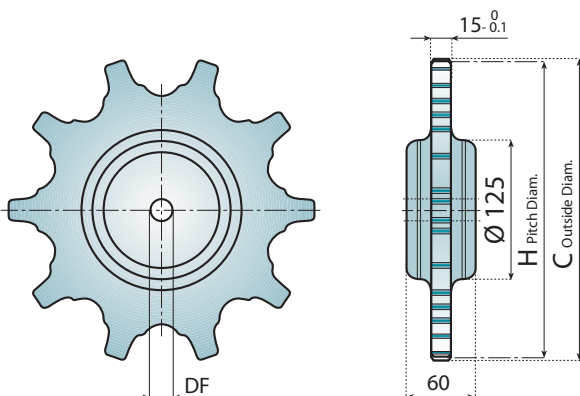

| CODE | Material | Z | C mm | H mm | DF mm | Weight Kg |
|-------|-----------|----|------|------|-------|-----------|
| 12331 | POLYAMIDE | 7 | 210 | 190 | 20 | 0.80 |
| 12332 | | 8 | 230 | 218 | | 0.90 |
| 12333 | | 9 | 257 | 242 | | 1.30 |
| 12334 | | 10 | 281 | 267 | | 1.90 |